



**SPY**  
**LABS**  
INCORPORATED

SCAN QR CODE FOR FULL-COLOUR MANUAL

LANGUAGES:

English, Deutsch,  
Français, Italiano,  
Español, Nederlands

AND MANY MORE



or go to: [www.kosmos.de/int/ForensicKit](http://www.kosmos.de/int/ForensicKit)



# Forensic Investigation Kit

**KOSMOS**

# Kit Contents



## Checklist:

✓	No.	Description	Qty.	Part No.
<input type="radio"/>	1	Laboratory base	1	725307
<input type="radio"/>	2	Vertical column, 4 holes	1	725308
<input type="radio"/>	3	Vertical column, 3 holes	2	725309
		Accessories for laboratory base:	725311	
<input type="radio"/>	4	Holder clip, 16-mm	2	
<input type="radio"/>	5	Holder clip, 38-mm	1	
<input type="radio"/>	6	Paper holder clip	1	
<input type="radio"/>	7	UV flashlight holder	1	
<input type="radio"/>	8	Tool holder	1	
<input type="radio"/>	9	Tall wide test tube	1	717120
<input type="radio"/>	10	Tall wide test tube lid	1	725313
<input type="radio"/>	11	Tall wide test tube cover with hole	1	725355
<input type="radio"/>	12	Small test tube with lid	2	725356
<input type="radio"/>	13	Lab report pad	1	726545
<input type="radio"/>	14	Sticker sheet (not shown)	1	726544
<input type="radio"/>	15	Tweezers	1	725357
<input type="radio"/>	16	Spatula	1	724052
<input type="radio"/>	17	Measuring spoon	1	720552
<input type="radio"/>	18	Pipette	1	714772
<input type="radio"/>	19	Filter paper	3	702842
<input type="radio"/>	20	UV flashlight	1	713927
<input type="radio"/>	21	Measuring cup	1	714771
<input type="radio"/>	22	Petri dish with lid	1	723751

✓	No.	Description	Qty.	Part No.
<input type="radio"/>	23	pH test strip	5	726333
<input type="radio"/>	24	Horse chestnut bark	1	775838
<input type="radio"/>	25	Fingerprint powder	1	721641
<input type="radio"/>	26	Brush	1	724970

## You will also need:

*1 AAA battery (1.5-volt, type LR03); small Phillips-head screwdriver; water-soluble black felt-tip pens or markers; baking soda; powdered sugar; cornstarch; black tea; lemon juice; household vinegar; various household liquids such as milk, apple juice, cooking oil.*

The additionally required items are listed in *italics* at the beginning of each experiment.

## Do you have any questions?

Our customer service will be happy to help you: [kosmos.de/servicecenter](http://kosmos.de/servicecenter)

# Table of Contents

<b>Kit Contents</b> .....	<b>2</b>
<b>A Note to Parents and Supervising Adults</b> .....	<b>3</b>
<b>Safety Information</b> .....	<b>4</b>
<b>Basic Rules for Safe Experimentation</b> .....	<b>5</b>
<b>Introduction</b> .....	<b>6</b>
<b>The Forensics Laboratory</b> .....	<b>7</b>
<b>The UV Flashlight</b> .....	<b>10</b>
<b>Analyzing Substances</b> .....	<b>14</b>
<b>Examining Evidence</b> .....	<b>18</b>
<b>Chromatography</b> .....	<b>20</b>

## Dear Parents and Supervising Adults,

With the Spy Labs Inc. Forensic Investigation Kit, your child can take on the role of a forensic investigator and conduct different scientific experiments used in real life investigations, like collecting fingerprints, analyzing evidence, evaluating writing samples, and much more!

The manual also provides fascinating background information as well as detailed explanations on each of the individual experiments. With concepts that are easy to understand and apply, the forensic laboratory materials can then be reused over and over for your child's own investigations and experiments.

Before starting the experiments, please read the manual together with your child and discuss the safety information. Support your child with advice and a helping hand when performing the experiments outlined in the manual. Make sure to keep the packaging and instructions as they contain important information. Keep the contents of this kit out of reach of pets and small children.

# Safety Information

**WARNING!** Not suitable for children under 3 years. Small parts. Choking hazard.  
Keep the packaging and instructions as they contain important information.

## Safety and disposal instructions for the UV lamp and the batteries

- > To operate the UV-lamp, you will need one AAA battery (1.5 Volt, type AAA/LR03), which could not be included in the kit due to their limited shelf life.
- > Only adults should insert, remove and replace the batteries.
- > The batteries are not to be short circuited. A short circuit can cause the wires to overheat and the batteries to explode.
- > Different types of batteries or new and used batteries are not to be mixed.
- > Batteries are to be inserted with the correct polarity (+ and -). Press them gently into the battery compartment. See page 10.
- > Non-rechargeable batteries are not to be recharged. They could explode!
- > Rechargeable batteries are only to be charged under adult supervision.
- > Exhausted batteries are to be removed from the toy.
- > The supply terminals are not to be short-circuited.
- > Dispose of used batteries in accordance with environmental provisions, not in the household trash.
- > Avoid deforming the batteries.

## Notes on disposal of electrical and electronic components

The electronic components of this product are recyclable/reusable.

For the sake of the environment, do not throw them into the household trash at the end of their lifespan.

They must be delivered to a collection location for electronic waste, as indicated by the following symbol:



Please contact your local authorities for the appropriate disposal location.



# Basic Rules for Safe Experimentation

All of the experiments described in this manual can be carried out safely if you follow these safety rules:

- > Read these instructions before use, follow them and keep them for reference. Pay attention to the quantities and the order of the single working steps. Only carry out the experiments described in this instruction book. Follow the notes given in the experiments.
- > Keep young children and animals away from the experimental area.
- > Store this experimental set and additional materials/household substances out of reach of children under 8 years of age.
- > Wear old clothes (or an old smock). Do not wear loose sleeves, a shawl, or a scarf while experimenting. Long hair should be tied back.
- > Clean all equipment after use. Clean your lab station and your work table and dry everything with a paper towel.
- > Wash hands after carrying out experiments.
- > Do not use any equipment which has not been supplied with the set or recommended in the instructions for use.
- > Do not eat or drink in the experimental area.
- > Be careful when handling the fingerprint powder, as it can stain carpets, clothing, and similar materials.
- > Do not allow chemicals, including the fingerprint powder, dust or household substances to come into contact with the eyes or mouth.
- > Always work slowly and carefully to avoid spilling and splashing chemicals and stirring up dust. Clean up spills right away with a paper towel.
- > Any materials not included in the kit are marked in italics in the “You will need” sections at the beginning of each experiment. Ask an adult to help you find the materials (e.g. sodium hydrogen carbonate, household vinegar, lemon juice, etc.) and have them ready before you start experimenting. Do not replace foodstuffs in original container. Dispose of immediately.
- > How to dispose of waste: Leftover liquid chemicals and residue can be poured down the drain with plenty of water. Dispose of leftover solids in the household garbage.

# Welcome Junior Detectives!



Welcome to Spy Labs Inc. We've tasked three of our best secret agents with getting you up to speed and teaching you some of the most important tricks of the trade. Allow me to introduce your new mentors.

*James Wright is the founder, chief detective, and top crime scene investigator at Spy Labs Inc. With a keen eye, he catches even the smallest of details. An excellent leader who trusts his team, James has a knack for identifying someone's unique skills and helping to develop them so everyone can do their best work. He is excited to learn more about your special talents and how you might contribute to the team.*

*Carolyn Lee is the deputy detective and lab technician. As athletic as she is perceptive, she is great not only at collecting evidence, but also at chasing down leads — sometimes literally! She is the main person responsible for analyzing the evidence back in the lab. All of Carolyn's lab experience has given her especially strong reasoning skills, almost like a sixth sense, making her the most rational member of the Spy Labs team.*

*Mike Franklin, the most organized in the group, is the detective in charge of research and archives at Spy Labs Inc. With his photographic memory and his robust library of data, records, and other research materials, Mike (nicknamed "the human search engine") can be counted on to find the information his team needs in a jiffy. After each case is complete, Mike compiles all of the evidence and puts together a detailed report.*

As a team, Spy Labs Inc. has already solved many exciting cases. You'll be assisting all three members of the team with solving cases by conducting research, collecting evidence, and analyzing it. With this forensics kit, you have everything you need to set up your lab, conduct your investigation, and track down the suspects!



## What is forensic science?

**Forensic science** (forensics for short) is the use of scientific methods to investigate crimes or examine evidence. In forensics, scientists examine evidence in a laboratory, often using chemical processes. Forensic science is a broad field with numerous disciplines, including fingerprint and DNA analysis, document and photo authentication, and sediment and shoe-print analysis. Most often, the task of a forensic scientist is to identify unknown substances. For example, a forensic scientist might examine a soil sample to trace its origin, which might help narrow down a list of suspects to those who live in a particular area. Another tool forensic scientists use is DNA analysis, which can be used to identify people who may have been at a crime scene.

# The Forensics Laboratory

## Welcome to Spy Labs Inc.

“What’s this?” James asks, as he walks in with a mysterious package left at the door of Spy Labs Inc. While examining it, in typical fashion, he begins to make observations. “A package ... wrapped in gray paper and clear tape ... wrapped carefully ... the address is written with a black felt-tip pen ... no sender’s name or address ...”

Carolyn, always keen on getting to the bottom of things, interjects sarcastically, “The interesting thing about packages is usually on the inside. I say we open it ... unless you want to stare at the packaging material a little longer.”

“This wouldn’t be the first time we’ve received a mysterious parcel,” chimes in Mike. “Yes, my records show we received one on December 24th!”

James continues turning the package in his hands, analyzing every inch. Realizing there is nothing more to note on the outside, he carefully removes the outer packaging, revealing a glossy box. Opening the flap, James begins taking the contents out one at a time, describing each in great detail as Mike transcribes his observations into his notebook.

Test tubes, a clear bowl with a lid, a flashlight, a black tray, clamps of different sizes — it wasn’t long before Carolyn concluded that the pieces seemed to all fit together. “This is a set of some kind!” she exclaimed, rushing in to assemble the mysterious components.

Stepping back, with a satisfied look on her face, Carolyn proclaims, “I knew it! It’s a mini forensics laboratory! This will make an excellent addition to our investigative equipment!”

## Assembling the forensics lab

**You will need:** Laboratory base, vertical columns, holder clips, tool holder

### Here’s how:

1. Use the tool holder to connect one large vertical column and one small vertical column.
2. Insert the two columns that are connected by the tool holder into the holes at the back of the base. The large column should be in the center, and the small column should be to the right. Insert the remaining small column into the empty hole to the left.
3. Fasten the holder clip for the large test tube to the left side of the middle column so that the bottom of the test tube can rest in the round indentation in the base. Attach

the remaining holder clips to the outer sides of the left and right columns.

4. Lastly, use the stickers to decorate your laboratory.



## Before Their Very Eyes

"Who would have sent this lab setup to us?" James wonders out loud. Examining the packaging again, on the inside of the outer wrapping, he finds a folded piece of paper. "There's a note!" he exclaims. "It reads ...

"Hello, Spy Labs Inc.

I hope you enjoy the contents of this package. But before you do, be sure to make yourselves comfortable. Might I suggest a strong cup of black tea?

X"

"Tea?" asks Mike.

"Did the mysterious X include some cookies as well?" jokes Carolyn. Just then, her eyes widen and she darts for the kitchen. "I don't think X wants us to stop and have a tea party," she yells from the other room. A few moments later, a high-pitched whistle can be heard coming from the kitchen and Carolyn returns to the room with a steaming cup of black tea. "I bet there's more on the note than meets the eye!" she declares, pulling a pipette from her pocket.

"Oh! Do you think it's a cipher?" asks Mike. "Let me get my notebook so I can write this down." "Exactly! And black tea is a substance that can make a hidden message visible!" Carolyn explains as she draws some of the tea into the pipette. As she dribbles the tea onto the note paper, a name gradually reveals itself.

"Jameela," reads James, "and a drawing of an ice cream cone. That makes sense. Who else would send a gift to all of us? Do you think she is telling us she needs something?"

## Make your own secret ink

### You will need:

Tall, wide test tube  
Petri dish  
Brush  
2 black tea teabags, lemon juice,  
piece of paper, warm water

### Here's how:

1. Fill the test tube halfway with warm (not hot) water and put the two teabags inside. Let it steep for at least 15 minutes, until the water has turned dark brown.





2. Place the petri dish in the well on the right side of the lab station and pour some lemon juice into it.

3. Dip the brush into the lemon juice and use it to write a message on the piece of paper. Once your message is composed, wash the brush. When the writing dries, it will be nearly invisible.

4. Remove the teabags from the test tube and dip the brush in the black tea, making sure to let any excess drip off. Sweep it over your piece of paper. The message appears again! Now you know how to write secret, invisible messages to your friends.

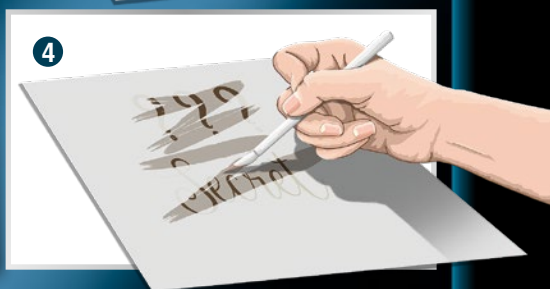

### What's happening?

Many dyes change color when an acid is added to them. Such dyes – including the dye in black tea – are called **indicators**. When the black tea comes into contact with the acid from the lemon juice, it changes color. Thus, the previously invisible writing becomes visible.

*Do not forget to clean the laboratory tools after each experiment.*

# The UV Flashlight

To use the UV flashlight, you must have an adult insert the battery.

Use a Phillips-head screwdriver to loosen the four screws on the bottom of the flashlight. The screws remain in the cover. Lift off the battery compartment cover. Remove the old battery, if applicable, and insert a new AAA battery (1.5-volt, type LR03), paying close attention to the polarity (+ and -). Place the cover back on and use the screwdriver to replace the screws. To turn it on, slide the switch forward (toward the bulb) and the LED will light up.

*Never shine the light into your eyes or those of other people or animals!*

## Revealing clues with UV light

### You will need:

The UV flashlight

### Here's how:

1. Darken one of the rooms in your home (make sure you can still make out your surroundings so you don't trip over or bump into anything) and look for clues with your UV flashlight. Investigate how different objects behave in the ultraviolet light. Look for things like paper and magazines, white or neon clothing, and highlighters.
2. Examine your fingernails, hands, and clothing under the UV light. Do you notice anything that you might not have seen under normal light?

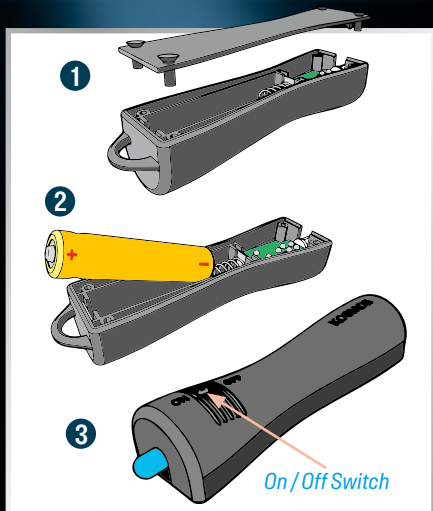

## What's happening?

In addition to a barely visible, dark-blue light, the UV flashlight primarily emits **ultraviolet (UV) light**. Generally, humans can see light with wavelengths between 380 and 700 nanometers (nm). All of the colors of the rainbow fall within that range, which is why we can see them. However, UV light has wavelengths shorter than 380 nm, which is why they go undetected by the human eye. When UV light bounces off objects that contain **phosphors** (substances that emit visible light in response to radiation), the phosphors become excited and naturally **fluoresce**, meaning they glow. Many everyday things glow brightly in the dark when exposed to UV light. Some examples are white clothing, highlighters, paper, but also dirt and stains. In forensics, UV light is used to make otherwise invisible or inconspicuous objects or spots (for example, blood stains) visible. Strong UV lights also help when checking gemstones, counterfeit money, and art for fakes.

## An Illuminated Idea

The three detectives grab their hats and walk the few blocks to Brain Freeze, the local ice cream parlor. Positioned at a table directly in front of the door sits Jameela, sipping on a root beer float. “Right on time! Fancy a cold treat?” she asks in her cheery British accent, looking up with a smile. Jameela has a keen mind for problem-solving, just like James, Carolyn, and Mike, but school and extracurricular activities — specifically the violin — make it so she can’t commit to being a full-time member of the team. She is thought of as an honorary member of Spy Labs Inc., always there to offer assistance when needed as well as presenting them with interesting cases and challenges.

“Got anything cool for us, Jameela? Get it? Because we’re in an ice cream parlor?” chuckles Carolyn, taking the seat next to her, while James and Mike slide into the seat opposite them.

Leaning over the table so she could whisper, Jameela says, “I’m going to need one of you to ...” she pauses, trying to find the right word, “... lift a wallet from someone.”

“Lift ... as in swipe?” asks Mike. “Wow, everything sounds nicer in British.”

“This is where she gives us a logical explanation. Or should I start listing all of the consequences of stealing?” interjects James, looking squarely at Jameela.

“Don’t worry. You won’t need to change the name of the company to Pickpockets Inc.,” she says with a laugh. “Money has been disappearing from the cash register at Brain Freeze. Ever since they told me, I’ve been spending my afternoons here, keeping an eye on the till while doing homework and drinking — a few too many — root beer floats. I have had a suspect in mind, but today we’ll be able to prove it. I’ve marked all of the bills in the cash register with a liquid that will fluoresce in UV light.”

James, smiling at Carolyn, says, “Well, this is a bit of a role reversal. Ok. I’ll try to swipe the wallet and pass it to Mike to take an inventory of what’s inside. Jameela, you can check the bills for a reaction to the UV light. Carolyn, you stand close by, just in case things go awry.”

## Marking paper money

### You will need:

Wide test tube, water, test tube cover with hole, bag of horse chestnut bark, spatula, brush, UV flashlight holder, UV flashlight, and a *banknote (paper money)*

### Here’s how:

1. Fill the test tube three-quarters of the way with water and then place it in the holder clip in your lab.
2. Use the spatula to put a few bits of horse chestnut bark in the test tube and seal the test tube using the cover with the hole.

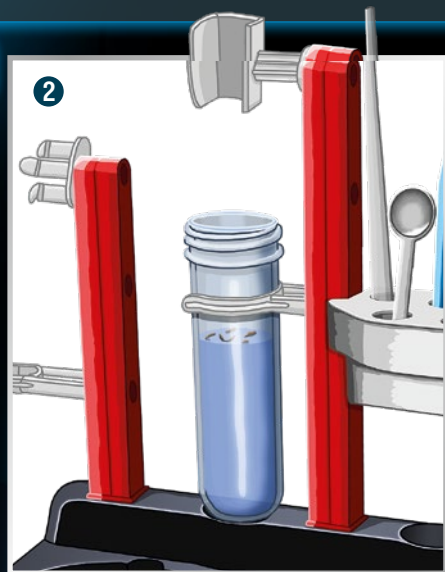

- Using the UV flashlight holder, clamp the UV flashlight to your laboratory station so that the LED shines directly through the hole in the cover of the test tube. Make a mental note of what the solution in the tube looks like in normal light.
- Turn on the UV flashlight and darken the lights in the room (or close the curtains). What do you see? In the UV light, as the bark floats in the water, it leaves behind a bright blue cloud that was not visible in normal light!

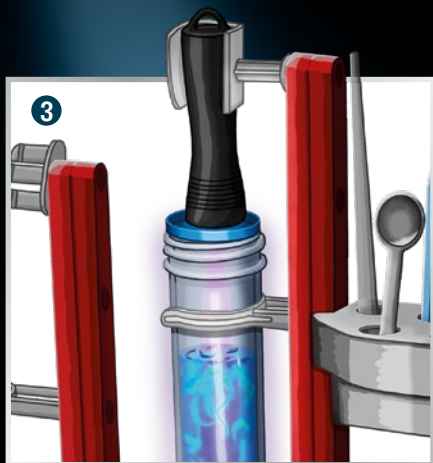

### What's happening?

Horse chestnut bark contains a water-soluble compound called **aesculin**, which glows under UV light, a property known as **fluorescence**.

- Turn the lights back on (or open the curtains) and remove the UV flashlight and the cover from the test tube. Use the spatula to stir the solution and remove the remaining bark from the test tube.

- Dip the brush into the UV solution and make a small mark on the banknote. Shine the UV flashlight onto the mark to make sure that it fluoresces (glows).



### Detective game!

Make a mark on a banknote and give it to your friend to hold for you. Later, when you ask for it back, see if it's the same bill by shining the light on it. If the mark you put on the bill doesn't glow, it's a different bill!



## A Sham on Mr. Shush

“Not that I’m complaining, but why do you think Carolyn asked us to meet her at the Public Library?” Mike asks mid-yawn. Re-alphabetizing the archive kept him up late the night before.

James shrugs, and they both look up to see Carolyn at the top of the stairs, waving at them. After exchanging greetings, she explains the situation to them. “I was here to return a book I borrowed, and I overheard a suspicious gentleman offering the library the opportunity to purchase a first edition of a book, published all the way back in 1851. He asked for very little money, considering its age, so Mr. Shush, the library’s manager, is skeptical.”

“Public libraries don’t get much funding,” James affirms, “so they have to be careful when it comes to purchases like these. And having the book tested for authenticity can be very expensive.”

Just then, Mike’s eyes light up and he runs over to one of the library’s computers. “I just remembered something. I recently read an article on how to narrow down the age of a book using UV light, as modern book pages use whitening agents.” After typing at his notably rapid speed, he shouts, “Here it is!”

James reads aloud, “In 1866, a process in which a hot, aqueous sulfuric acid solution was used to dissolve lignin, the substance that causes oxidation and yellowing of book pages, was developed.”

He thinks for a moment and explains, “So if this book glows under the UV light, that means bleaching agents are present, so it can only have been printed after 1866. That would confirm whether or not it is authentic!”

## Authenticating an old book

### You will need:

UV flashlight

Lab report pad

*Different types of household paper*

### Here’s how:

1. Collect different types of paper (e.g., printer paper, notebook paper, bathroom tissue, paper towel, cardboard) and, in a darkened room, examine each under the UV flashlight.
2. Make notes of how each different paper reacts to the UV light on a sheet from your lab report pad.



### What’s happening?

**Whitening agents** have been added to most types of paper for years, making the paper appear whiter and cleaner. These whiteners are substances that convert ultraviolet radiation into bluish light, which transforms the natural, yellow color of paper into the bright white that we recognize today. Because of these whitening agents, paper that has been through this process glows blue in UV light. Conversely, because these whiteners were not discovered until 1866, UV light can be used to distinguish older books or documents from newer ones.

# Analyzing Substances

It is crucial for detectives to know exactly what kind of substances they are dealing with. If a mysterious liquid or powder is left at a crime scene, finding out what the substance is composed of and what its properties are is very important. Is the liquid an acid, a base, or neutral? Does the powder dissolve in water, or is it insoluble? The following experiments will show you how to analyze mysterious substances.

## Acid test

### You will need:

2 Small test tubes  
Spatula  
Measuring spoon  
Lab report pad  
*Baking soda, different household liquids (e.g., water, milk, lemon juice, cola, herbal tea, cooking oil, lemonade, apple juice)*

### Here's how:

1. Attach the two test tubes to your lab station using the holder clips and add a different liquid to each one.
2. If small bubbles form in either of the liquids, stir it with the spatula until no more bubbles can be seen, (otherwise, you won't be able to clearly observe the reaction with the baking soda).
3. Add a scoop of baking soda to each of the test tubes and observe what takes place.
4. After recording your observations in your lab report pad, wash out the test tubes and perform the experiment on two additional liquids.



### What's happening?

**Acids** are substances that neutralize **alkalies** (bases) and have a caustic effect – meaning they can dissolve other substances. Typically, acids have a sour taste. We come into contact with acids every day, as they are used for food preservation and are added to drinks. For example, carbonic acid is added to soft drinks to make them fizzy. When the bottle is opened, the pressure decreases and the carbonic acid changes into carbon dioxide and water. When baking soda comes into contact with an acid, a chemical reaction causes **carbon dioxide** to form, which causes bubbles to rise up in the liquid. For non-acidic liquids, no such reaction happens.

## The pH test

### You will need:

2 Small test tubes  
pH test strips  
Lab report pad  
*Different household liquids*  
(e.g., milk, lemon juice, cola, herbal tea, apple juice)

### Here's how:

1. Attach the two test tubes to your lab station using the holder clips and add a different liquid to each one, just like in the baking soda experiment.
2. Dip one of the pH test strips into each test tube and observe how the test strips change. They will begin to change color!
3. Compare the result with the color scale below and your notes from the previous experiment.

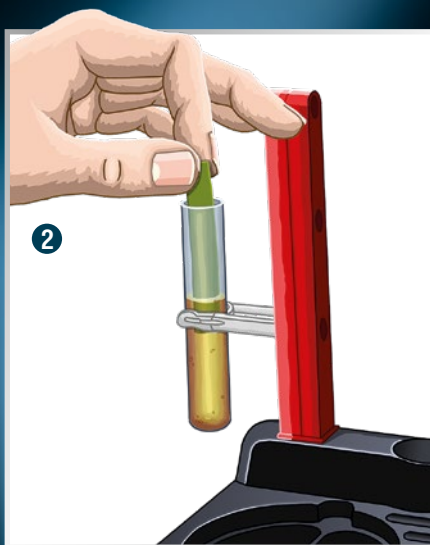

### What's happening?

Like the black tea in the secret ink experiment (pages 8 and 9), the dye in the test strip is an **indicator**. It changes color depending on the **pH** (a value that indicates how acidic a liquid is) of the substance it comes into contact with. The test strips can tell you not only if the liquid is an acid, but it can also tell you how acidic it is (or if it is a base, which is the opposite of an acid). If a liquid is neither acidic nor alkaline (meaning having the properties of a base), it is called **neutral**.

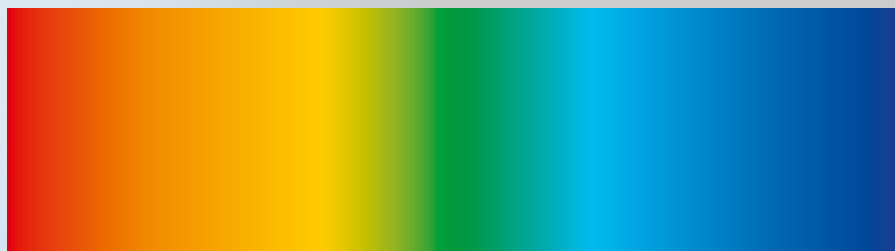

Highly  
acidic

Slightly  
acidic

Neutral

Slightly  
alkaline

Highly  
alkaline

## Mrs. Wright's Mishap

The detectives at Spy Labs Inc. are putting in extra time, due to an influx of requests that have been coming in lately. James' stomach growls loud enough for Carolyn and Mike to hear, and they all begin to chuckle. "I think that means it's time for a break, team," he jokes, motioning for the rest of the team to follow him into the kitchen.

"Oh, yuck! What on Earth was I thinking?" James' mom asks herself as she wipes her tongue with a napkin. She looks over at the counter, sighing at the five jars she has laid out.

"What's wrong, Mrs. Wright?" Carolyn asks, standing next to her.

"Oh, hi kids," she replies. "I made a silly mistake. I bought some baking ingredients today — salt, sugar, powdered sugar, corn starch, and baking soda — and I poured them into jars to keep them fresh, but I didn't label them as I was filling each. So now I have five jars with white powders in them. I was able to figure out which was sugar and which was salt, but I can't figure out which of the finer powders is which. When I tried the first one ... Yuck! I'm not doing that again! I need to find out what's in those other three jars so that I don't ruin my recipes."

Mike chimes in, "I know! We can use water and vinegar to identify the corn starch and the baking soda! And then the one that doesn't react is the powdered sugar!"

## Identifying mysterious powders

### You will need:

Measuring spoon  
Pipette  
2 Small test tubes  
Spatula  
Lab report pad  
*Powdered sugar, baking soda, cornstarch, household vinegar, water*

### Here's how:

1. Have someone fill each of the three wells in your lab station with powdered sugar, baking soda, and corn starch (making sure not to cross-contaminate them). Make sure they don't tell you which is which!





2. Fill one test tube with water and the other with household vinegar.
3. Fill the pipette with water and add a few drops to each of the three powders. Observe how they behave when the water is added, and then stir it with the spatula. Record your findings in your lab report pad.



### What's happening?

The powdered sugar and the baking soda will **dissolve** in the water so you can't see any of it, but the cornstarch clumps up at first and then turns into a cloudy mixture as you stir it. This is because the particles in the cornstarch are much larger than the powdered sugar and baking soda particles, which makes it less **soluble** in water.

So now you know which well contains the cornstarch. Write down your findings on the lab report pad.



4. Now empty the pipette and fill it with household vinegar. Put a few drops in each of the three wells.



### What's happening?

The baking soda reacts with the vinegar, forming bubbles and releasing carbon dioxide (which you learned in the acid test experiment on page 14). So now you know which powder is the baking soda! No reaction is observed in the other two wells, however you have already identified the cornstarch. That means that the powder that dissolved in water and didn't react to the vinegar is the powdered sugar! You have successfully identified all three substances without tasting them. Note your results on your lab report pad.

# Examining Evidence

## Lifting fingerprints

Every year, thousands of identifications are made using fingerprints found at crime scenes, which is why they are so important to detectives and criminalists. The reason these identifications are possible is that every person has different patterns on their fingertips, which do not change throughout the entirety of their life. You can use the fingerprint powder to search for evidence! Think about objects or surfaces that a perpetrator may have touched with their hands and dust the area for prints.

### You will need:

Fingerprint powder

Brush

Clear adhesive tape, sheet of white paper, pen

### Here's how:

1. Tap the lid of the fingerprint powder container a few times to level the powder and make sure none is stuck on the inside of the cap. Carefully unscrew the lid to avoid spilling any powder.
2. Dip the brush into the powder. Holding the end of the brush over the fingerprint, tap the handle gently so some of the powder falls from the brush onto the print. Spread the powder very carefully with the brush and sweep away or gently blow off any excess powder.
3. With a piece of clear adhesive tape, you can now **lift** the fingerprint, which means to preserve a copy of it. To do this, press the piece of tape with the adhesive side down onto the visible fingerprint and use your finger to smooth out the tape, making sure there are no creases or bubbles. Now, peel the tape off of the surface. The fingerprint will be on the tape!
4. Next, archive your evidence by attaching the tape, adhesive side down, to a piece of white paper. Write down where and when you found the fingerprint and who you think may have left it.



## What we can learn from soil samples

Did you know that the bottoms of your shoes pick up residue that can tell investigators a lot about where you've been? Small clippings of grass indicate you walked through a freshly cut lawn. Pieces of fallen leaves indicate you've walked through a deciduous forest, while pine needles are indicative of a coniferous forest. Sand, gravel, and soil can clearly be distinguished under a magnifying glass. But if you don't have a magnifying glass at hand, you can also identify them with your forensics lab, using a petri dish and a drop of water.

### You will need:

Lid of the petri dish  
Pipette  
Measuring cup with water  
Tweezers  
*Soil samples*

### Here's how:

1. Collect three soil samples from various locations and place a small amount into each of the three wells in your lab station. If it is clumped together, use the tweezers to break the sample apart.
2. Place the lid of the petri dish on top of the three wells (like a lid). Draw some water into the pipette, and squeeze a drop of water onto the lid over each of the different soil samples.
3. Now, look at the samples through the water drop. It enlarges them like a magnifying glass! Now you can analyze each of the soil samples and take notes in your lab report pad. What color is the sample? Are there any granules or pebbles? Can you see any plant remains and, if so, what do they look like?



# Chromatography

## A Note With No Name

"Is everything okay, Jameela? What are you looking at?" asks Carolyn, running up to her friend in the school's hallway. She could tell by the look on her face that something was puzzling her.

"Check out this note that someone slipped into my jacket pocket yesterday," she says, handing Carolyn a piece of tracing paper with some black writing on it. Her eyes widen as she reads the note. She waves for James and Mike to come over.

"Listen to this note someone wrote to Jameela," she says as she begins to read aloud. "You've been pranked! I have hidden your violin. Find out who I am, and you just might get it back before the big concert at the end of the week!"

"There's a long tradition of the senior orchestra members pranking the younger ones like this," Jameela explains.

"Do you have any idea who could have written this note?" asks James.

Jameela thinks for a minute and responds, "I found it on my way home yesterday, which makes sense because I had orchestra practice after school. Ms. Clef, the orchestra teacher, told us during practice that I had been picked as the violin soloist for the upcoming concert ... which is why I'm being pranked now. I have to find out who wrote this note and get my violin back! I have to practice!"

Examining the note, James says, "We don't have any solid suspects yet, so let's collect some handwriting samples." He hands the note to Mike.

"While we can't be sure, I have a feeling that whoever wrote this tried to disguise their handwriting by using all capital letters," Mike thinks aloud. "Jameela, do you think you can get everyone to sign a piece of filter paper, using their own pen, without it seeming suspicious?"

Jameela thinks for a moment and says, "I can tape it to the inside of a birthday card for Carolyn! It's not until next month, but they don't know that." She nudges Carolyn with her elbow and they both chuckle.

The next day, the team gathers around the forensics lab. "Nope. No handwriting matches. And everyone used black pen," laments Carolyn. "I think your hypothesis was right, Mike."

"Luckily, we got everyone's signature on the filter paper!" exclaims Mike. "Since we can't distinguish the handwriting, and the ink cannot be distinguished with a magnifying glass alone, we will use a process called chromatography to try to match the inks and find out who the writer was!"

The team carefully conducts the chromatography analysis on the original handwriting sample from the note and the samples from the birthday card.

"We have a winner," James declares, checking the results. "Assuming she used the same pen each time, our prankster is ... Melody!"

"Ha! Gotcha!" Jameela yells as she races off to find Melody and her violin. "Thank you, sleuths!"



## Climbing colors

### You will need:

Petri dish  
Filter paper  
A few different black, water-soluble, felt-tip pens or markers; tape;  
scissors; water

### Here's how:

1. Fill the front well of the lab station with water.
2. Write the word "secret" on one of the filter papers with a black felt-tip pen. The writing should be about 1 cm (about a half inch) from the edge of the filter paper.
3. Use the scissors to cut a slit in the filter paper from the edge to the center. Then, gather the filter into a cone. Secure it with a piece of tape, making sure the tape doesn't cover your writing.
4. Place the cone in the water for about a minute and allow the water to slowly climb up the filter paper.
5. Repeat the experiment with a second piece of filter paper and a different black marker. Once you have two or more examples, compare them. What do you see?



### Not like the others

Ask a friend to write a word on one of the filter papers using a different pen for only one of the letters. Using chromatography, can you identify which of the letters is written in different ink than the others?



### What's happening?

The water-soluble pigments in the ink are being transported upward along with the water as it climbs up through the filter paper. Because black ink is a **mixture** of different colors, as the water moves upward, the soluble ink is separated into those individual pigments. Each of the pigments has different properties, and some of them dissolve in water more easily and are thus pulled farther up the filter by the climbing water. This chemical analysis method is called **chromatography**. It is often used in forensic investigations to separate a mixture into its component parts.



3. Next, focus in on the shape and characteristics of each letter. Does the writer connect letters together with a line? What do the curls and loops look like in letters like o, e, and s? Do lowercase letters with “ascenders” (letters with an extension that rises above the mean line, like h, l, and f) stand out well above the rest of the writing, or are they almost level? What does the dot in a lowercase i look like (a dot, a circle, a line, or something else)?

4. The fewer differences you can find between a known sample and the document in question, the more confident you can be that they are from the same writer.



4



## Imprint

0727423 AN 010323-EN / Master\_1632311  
Manual for „Forensic Investigation Kit“, item no. 7617264

© 2023 Franckh-Kosmos Verlags-GmbH & Co. KG, Pfizerstraße 5-7, 70184 Stuttgart, DE,  
Tel. +49(0) 711 2191-343

This product and all of its parts are protected by copyright. Any use outside of the narrow copyright law limits is not permitted without the publishing house's approval and is punishable.

This especially applies to reproductions, translations, microfilming and storage and processing in electronic systems, networks and media. We assume no guarantee that all information in this product is free of property rights.

Project manager: Ricardis Roth  
Technical product development: Björn Stolpmann  
Text: Cindy Jäger  
Product design: Manuel Aydt, Crosscreativ Designstudios, Pforzheim  
Packaging and manual layout: Michael Schlegel, komuniki – print + web (Würzburg)  
Illustrations: Tanja Donner, Riedlingen  
Cover Illustration: Andreas Ruch, Düsseldorf  
Photos: p. 3 (contents photo, Michael Flaig)

The publishing house had made every effort to find the owners of the image rights for all photos used. If an image right holder was not taken into consideration in individual cases, we ask said holder to prove ownership of the image right to the publishing house so that the publishing house can pay the photo fee to the right holder that is standard for the industry.



# **SPY LABS** INCORPORATED

## Attention Junior Detectives!



Protect your secrets



Marking and tracking locations



Analyze evidence and solve cases

Do you have  
any questions?  
Our customer services  
will be happy to help you!

KOSMOS customer services  
Tel.: +49 (0)711-2191-343  
Fax: +49 (0)711-2191-145  
service@kosmos.de

© 2023 KOSMOS Verlag  
Pfizerstraße 5-7  
70184 Stuttgart, DE  
kosmos.de